



Product Specification  
**CATALOGUE**  
AGRICULTURE DIVISION



# Table of Contents

---

Product Profile.....	3
Electric Waterers .....	4
Energy Free Waterers .....	6
Tip Tank Waterers .....	8
XL Series Waterers .....	10

Parts & Accessories .....	13
Installation Considerations .....	14
Contact.....	15

## Product Profile

---

SPI's livestock waterers are built of a polyethylene construction, creating a strong, corrosion free product designed to provide years of trouble-free operation.

Our low maintenance, easy-to-clean, polyethylene products are FDA and HPB approved, food grade, recyclable plastic. All our livestock waterers meet "Grade A" Dairy requirements.

SPI's waterers are designed with rounded corners to handle livestock abuse while ensuring livestock safety.

SPI's Electric, Energy free and XL Series livestock waterers contain insulated bases constructed of a double wall filled with an insulated foaming material.

Water levels are controlled by a float-operated valve which when triggered by the decline in water opens and allows water from a pressurized water line to flow and refill to a set, yet adjustable, water level.

SPI stands behind their product 100% and we guarantee quality. That is why SPI offers a 10 Year limited warranty on our products.



# Electric Waterers



Model No. **VS20E**

## Special Features

- No Tools Required.
- A water flow outlet between compartments allows quicker transfer of heat while still protecting the valve area.
- Large drain plug for quick and efficient emptying.
- Solid polyurethane foam insulation keeps water ice-free longer in winter and cooler in summer.
- Livestock can access water from two bowls.



Model No. **VS15E**

## Special Features

- No Tools Required.
- Large drain plug for quick and efficient emptying.
- Solid polyurethane foam insulation keeps water ice-free longer in winter and cooler in summer.

MODEL	LENGTH IN/CM	WIDTH IN/CM	HEIGHT IN/CM	WEIGHT LBS/KG	DRINKING HEIGHT IN/CM	CAPACITY LITRE/US GAL/IMP.GAL.
VS20E	32/81	22/56	26/66	54/24.5	19/48	35/9.2/7.7
VS20LPE	28/71	21.75/55	16/40.5	32/14.5	12/30.5	20/5.3/4.4
VS15E	27/68.5	22/56	26/66	40/18	19/48	18/4.8/4
EE10NG	17/43	17/43	13.5/34.5	26/12	11/28	11/2.9/2.4



Model No. **VS20LPE**

### Special Features

- No Tools Required.
- Large drain plug for quick and efficient emptying.
- Livestock can access water from two bowls.
- Solid polyurethane foam insulation keeps water ice-free longer in winter and cooler in summer.
- Accessible Shutoff for valve included.

Model No. **EE10NG**

### Special Features

- No Tools Required.
- Large drain plug for quick and efficient emptying.
- Solid polyurethane foam insulation keeps water ice-free longer in winter and cooler in summer.
- Can be mounted to the floor or wall.

MAXIMUM USAGE Livestock usage varies per waterer unit	SUBMERSIBLE HEATER & HEAT TAPE	NON-HEATED VERSIONS AVAILABLE	
100 Beef; 50 Dairy; 50 Horses; 200 Sheep	500 WATT	✓	
60 Beef; 25 Dairy; 30 Horses; 75 Sheep; 65 Hogs	500 WATT	✓	
60 Beef; 25 Dairy; 30 Horses; 150 Sheep	500 WATT	✓	
Less than 10 head; or single stall use	500 WATT* *HEATER ONLY, NO HEAT TAPE		

# Energy Free Waterers



Model No. **354NG**

## Special Features

- No Tools Required.
- Exclusive Double Seal, featuring aqua seal and foam gaskets, ensures an airtight seal between the lid and the base.
- Solid polyurethane foam insulation keeps water ice-free longer in winter and cooler in summer.
- Patented door closure system which prevents door freeze up, contamination by birds and protects against mosquito breeding, lowering the risk of spreading West Nile Virus.

MODEL	LENGTH IN/CM	WIDTH IN/CM	HEIGHT IN/CM	WEIGHT LBS/KG	DRINKING HEIGHT IN/CM	CAPACITY LITRE/US GAL/ IMP.GAL.
354NG	41/104	36/91.5	19/48	92/42	15/38	150/40/33
352NG	41/104	23/58.5	20/51	75/34	15/38	83/22/18
351NG	28/71	23/58.5	20/51	50/23	15/38	64/17/14



Model No. **352NG**

Model No. **351NG**

<b>MAXIMUM USAGE</b> Livestock usage varies per waterer unit	<b>DOOR OPENING</b> IN/CM	
200 Beef; 90 Dairy; 200 Elk, 90 Horses; 300 Sheep	9.5X9.5/24X24	
150 Beef; 70 Dairy; 150 Elk, 70 Horses; 250 Sheep	9.5X9.5/24X24	
120 Beef; 50 Dairy; 120 Elk, 50 Horses; 135 Sheep	9.5X9.5/24X24	

# Tip Tank Waterers



Model No. **TIPTANK7,NG**

## Special Features

- No Tools Required.
- Only Tip Tank in the industry with the mounting hardware encased within the waterer, providing animal safety and security, as well as, protecting the moving parts of the Tip Tank.
- Ultimate in water access, service and cleaning.
- Wall or floor mounted.

MODEL	LENGTH IN/CM	WIDTH IN/CM	HEIGHT IN/CM
TIPTANK7,NG	93/236	24/61	24/61
TIPTANK4,NG	58/147	24/61	24/61





Model No. **TIPTANK4,NG**



Image of tank tipped.

WEIGHT LBS/KG	DRINKING HEIGHT IN/CM	CAPACITY LITRE/US GAL/IMP.GAL.	MAXIMUM USAGE Livestock usage varies per waterer unit
100/45	21/53	152/40/33	135 Beef; 70 Dairy
85/39	21/53	80/20/18	75 Beef; 40 Dairy

# XL Series Waterers



Model No. **12XL**

## Special Features

- No tools required.
- Large drain plug in the center of the unit allows for rapid draining.
- A rounded, smooth basin with a tapered floor bottom prevents the collection of dirt and manure in corners, making the unit easy to clean and maintain.
- A ground rod is included.
- Solid polyurethane foam insulation keeps water ice-free longer in winter and cooler in summer.
- Submersible heater and self regulating heat tape optional for freezing conditions.

MODEL	LENGTH IN/CM	WIDTH IN/CM	HEIGHT IN/CM	WEIGHT LBS/KG	DRINKING HEIGHT IN/CM	CAPACITY LITRE/US GAL/IMP. GAL.
12XL	144/370	23.5/60	24/61	235/107	24/61	265/70/58
10XL	115/290	23.5/60	24/61	185/84	24/61	225/59/49
7XL	84/210	23.5/60	24/61	150/68	24/61	132/35/29



Model No. **10XL**

Model No. **7XL**

MAXIMUM USAGE Livestock usage varies per waterer unit	DRAINING TIME SECONDS	SUBMERSIBLE HEATER & SELF REGULATING HEAT TAPE OPTIONAL FOR FREEZING CONDITIONS	
500 Beef; 250 Dairy	40	✓	
420 Beef; 210 Dairy	30	✓	
250 Beef; 125 Dairy	20	✓	



## STOCK TANK WATERERS

Lightweight and durable.



MODEL	LENGTH IN/CM	WIDTH IN/CM	HEIGHT IN/CM	WEIGHT LBS/KG	CAPACITY LITRE/ US GAL/ IMP GAL	USAGE
150 GAL	71.5/182	31.5/80	24.5/62.5	45/20	568/187/150	Cattle, Horses, Elk/Deer, Emu
100 GAL	52/132	27/67	24/61	29/13	379/125/100	Cattle, Horses, Elk/Deer, Emu
35 GAL	44/111	22/56	11.5/29.5	16/7	132/44/35	Sheep/Goats, Water Garden, Pet Bath

## HAYKNIFE™

Lightweight hay feeding knife, cuts twine, mesh and plastic wrap, with twine pulling capabilities.

Flip action blade operation and safety cover.

Replaceable blade, indestructible handle, ease of use with gloves.

Precision two handed cutting for drywall, carpet, ty-par and roofing materials.



## SUBMERSIBLE HEATER

Part # HEATER,VS,500

- Includes built-in thermostat
- 500 WATT



## HEAT TAPE

Part # VS20,HEATTAPE

- Includes built-in thermostat. Reduces heat as the temperature rises but never completely shuts off
- For use on supply line and valve



## OVAL FLOAT WITH STEM AND VALVE

Part # 118 – BLUE



## OVAL FLOAT

Part # 204



## VALVE

Part # 122 – BLUE



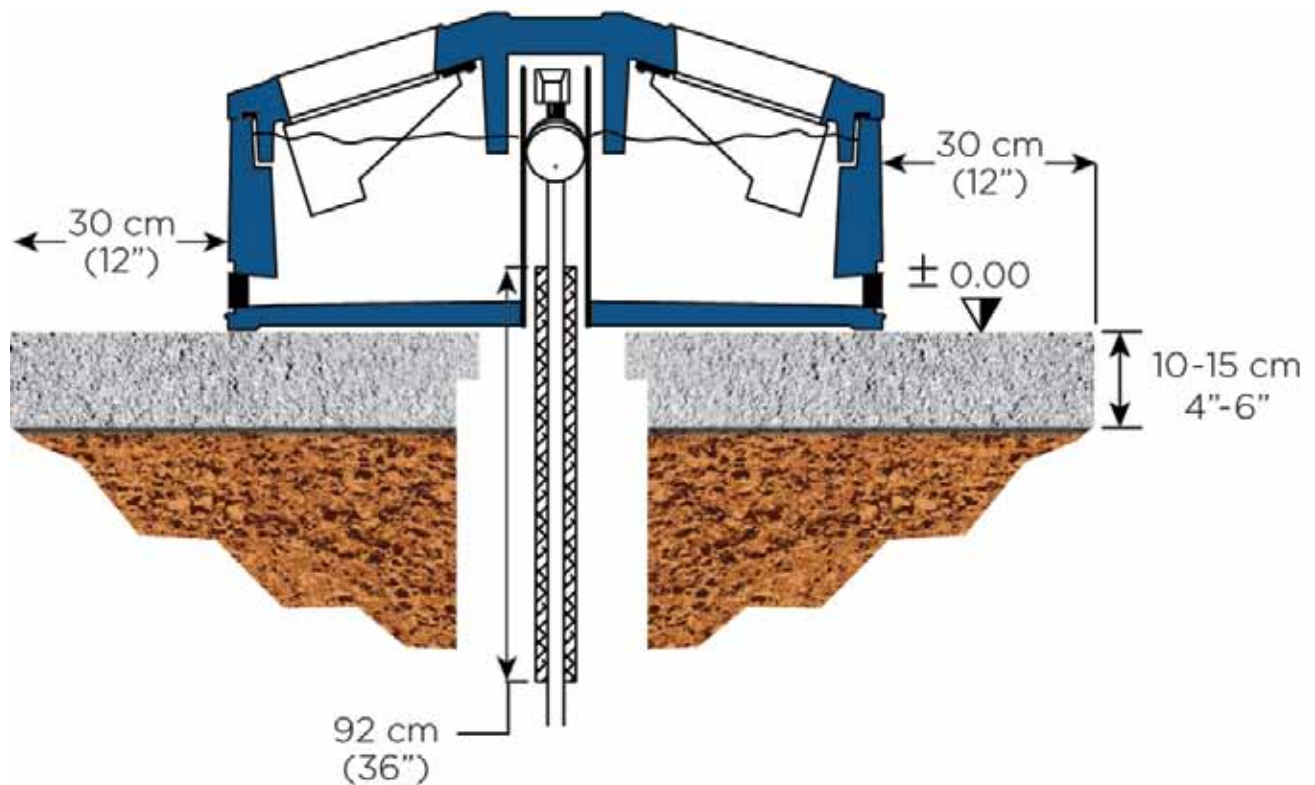

## Installation Considerations

The location of your waterer is important. Protection from wind and snow reduces energy costs, particularly on the electrical units, and helps prevent freezing. Easy access for livestock must also be considered.

A concrete pad for the waterer to sit on will assist with drainage and prevent a mud hole from forming. The base of the waterer should be caulked or weather stripped to the concrete pad to reduce the wind penetration.

If you are installing an electrical unit be sure to have installation completed by a qualified electrician and according to all applicable electrical codes for your area. You will require a properly grounded receptacle outlet, acceptable for outdoor use and protected from the rain and snow.

A water supply line should be run below the ground frost line and up to the waterer location through a 12" diameter tube.

A minimum number of animals drinking from the waterer will keep the water moving, and will also assist in the prevention of freezing.

Regular maintenance and cleaning of the unit ensures livestock are receiving clean water and helps prevent freezing as well.

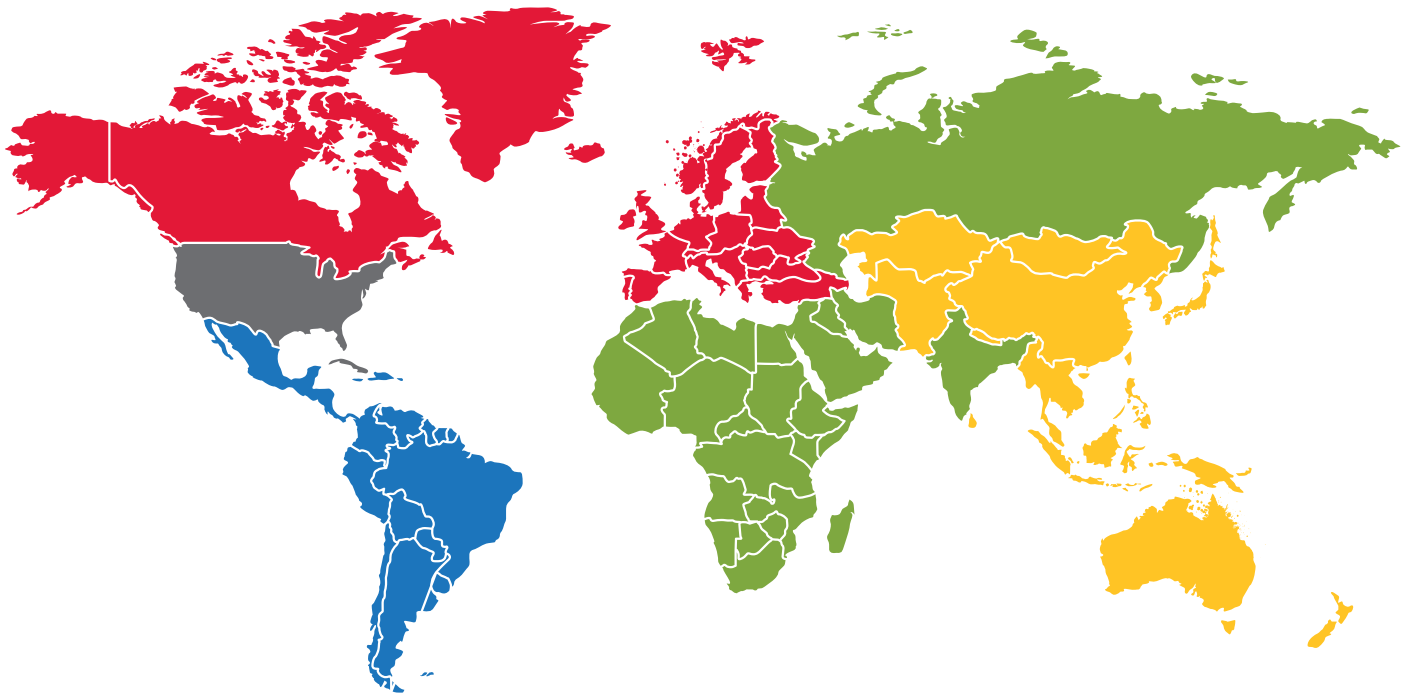

## Contact

---

After many years, SPI's product line continues to perform as the most advanced design in livestock waterers. Continuous improvements and added innovations have made our product the obvious choice for livestock operators who understand the meaning of quality product and simplicity of function.

SPI provides "hometown personal service" while exporting product to over 40 different countries worldwide. Whether its a single water bowl to a waterer that can accommodate 500 cattle, SPI can get you what you need.

CALL US TODAY  
**800-269-6533**

JAKE FREE  
Customer Service Representative  
Agricultural Department

[P] 519-935-2211  
[T] 800-269-6533  
[F] 519-935-2174

[jfree@spiplastics.com](mailto:jfree@spiplastics.com)

165 STONEMAN DRIVE, BOX 100  
SHALLOW LAKE ONTARIO, CANADA  
N0H 2K0



DISTRIBUTED BY



**800-269-6533**

**[www.spiplastics.com](http://www.spiplastics.com)**

