

Frog and Whale Riding Animals

Supplied Part: Riding Animal

Suggested Parts*: 1 Spring, (4) - 3/8" X 1 1/4" Button Head Bolt, Flat & Lock Washers.

Refer to Suggested Spring Assembly Mounting Parts List on last page.

*Parts must be provided by the installer but can also be purchased from SPI Industries.

Step 1 —

Make a *Wooden Jig* to ensure proper fit and clearances of Spring Mounting Plate.

Wooden Jig Dimensions —

Top View

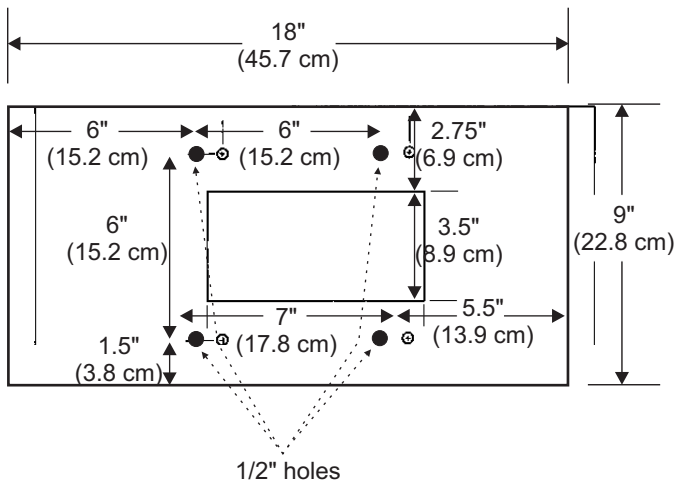

Side View

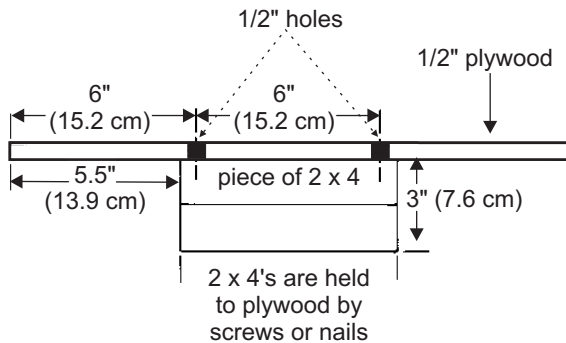

Wooden Jig with "J" Bolts Installed

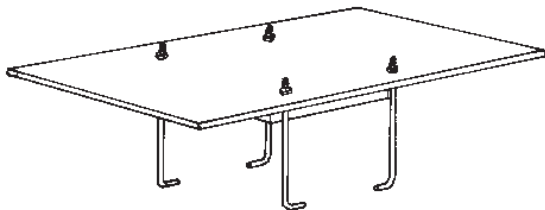

Step 2 —

Dig a hole suitable for a 36" (91.4 cm) long piece of 15" (38.1 cm) diameter *Sonotube* and place the *Sonotube* in the hole.

Fill the hole with concrete flush to ground level and press the *Wooden Jig* into the cement leaving a 1" (2.5 cm) gap between the underside of the jig and ground level.

Allow 24 hours for the concrete to set and dry.

Note: If using existing concrete footing, drill appropriate holes into the concrete and hammer in the bolt anchors. Drill or chisel a 7" long x 4" wide by 2" deep hole for bottom bolt clearances. Mount and level the *Spring Assembly* then proceed to Step 4. Be sure to check with the appropriate authorities before digging the hole.

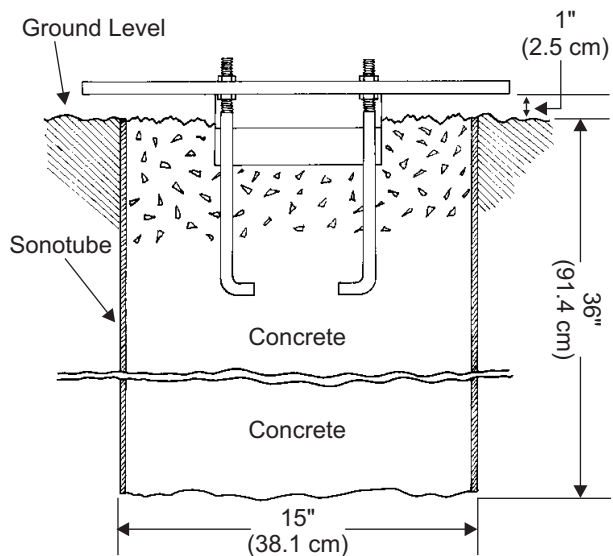

Frog and Whale Riding Animals

Step 3 —

After 24 hours, remove the *Wooden Jig* from the "J" Bolts and attach the *Base Plate* of the *Spring Assembly* to the "J" Bolts.

Ensure the *Base Plate* is level by adjusting the *Leveling Nuts* on the "J" Bolts. Securely tighten the nuts.

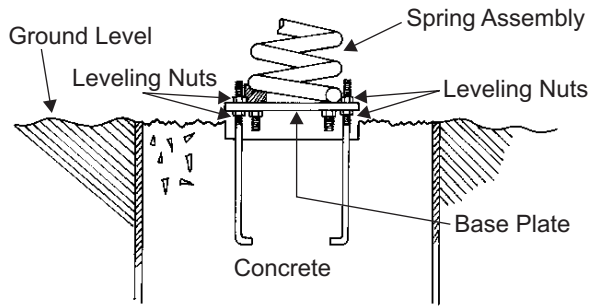

Step 4 —

Attach the *Riding Animal* to the *Body Anchor Plate* of the *Spring Assembly* using the supplied 5/16" x 3/4" Hex Head Bolts. Ensure all bolts are securely fastened.

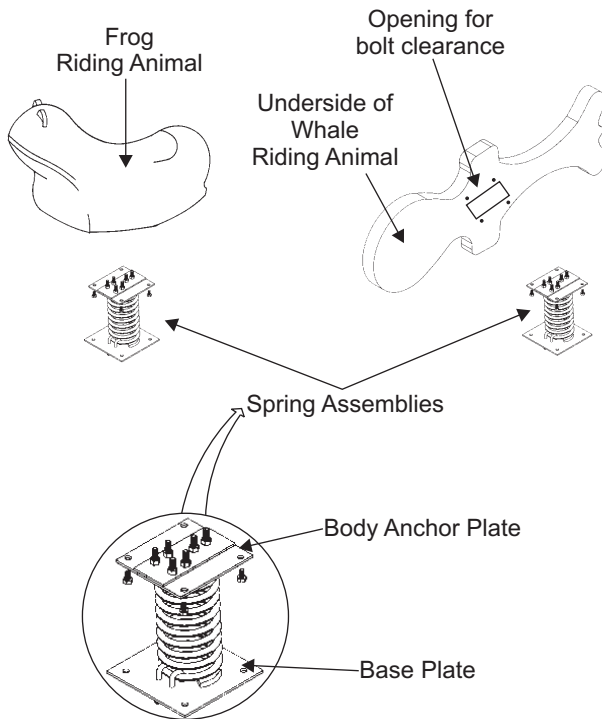

Step 5 —

Perform a final inspection ensuring that all bolts and nuts are firmly tightened and everything has been properly assembled.

Place sufficient surfacing 6" - 9" (15 cm - 23 cm) around the *Riding Animal* to comply with CSA/ASTM guidelines and to cover the bottom portion of the *Spring Assembly*.

Suggested Spring Assembly Mounting Parts List — Riding Animals

Parts must be provided by the installer.

If pouring new concrete footing

Quantity Part

| | |
|---|-----------------------|
| 4 | 1/2" x 10"- "J" Bolts |
| 8 | 1/2" Hex Head Nuts |
| 4 | 1/2" Lock Washers |

If using existing concrete footing

Quantity Part

| | |
|---|------------------------------|
| 4 | 1/2" x 3" Anchors |
| 8 | 1/2" x 2 1/2" Hex Head Bolts |
| 4 | 1/2" Lock Washers |