

7

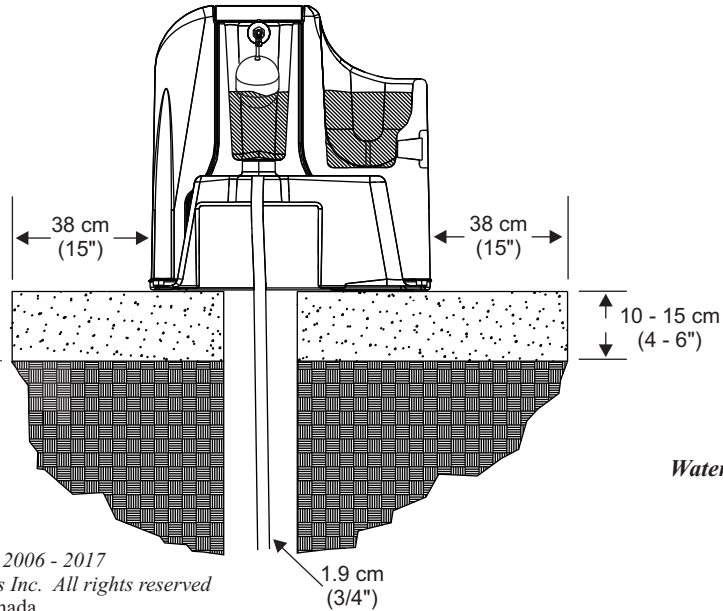

Water Pressure: Please note the valve is appropriate for water pressure up to 55 psi.

Copyright © 2006 - 2017
SPI Industries Inc. All rights reserved
Printed in Canada

Updated: July 2015

Installation of the Model C-500 Submersible Heater

* The Model C-500 is safe to use in plastic and structural foam tanks.

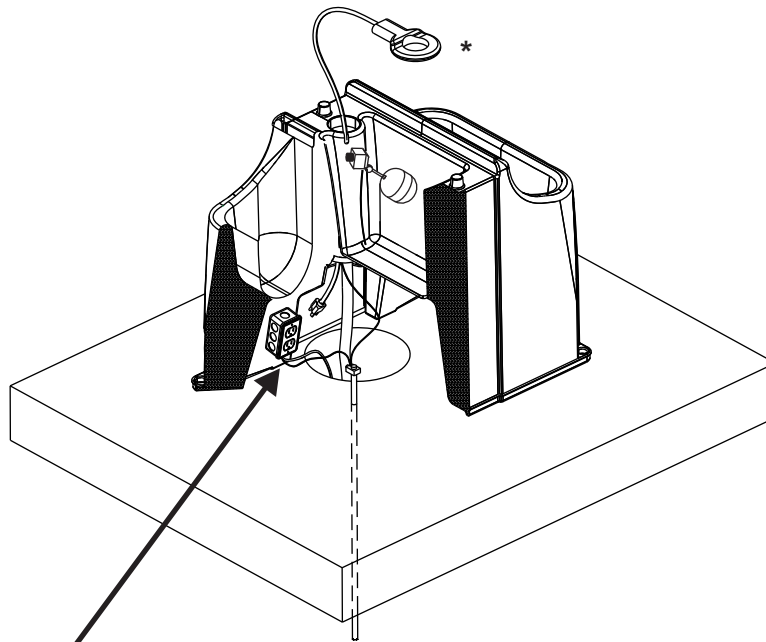

Have a qualified electrician install a properly grounded receptacle outlet, acceptable for outdoor use and protected from the rain and snow

1

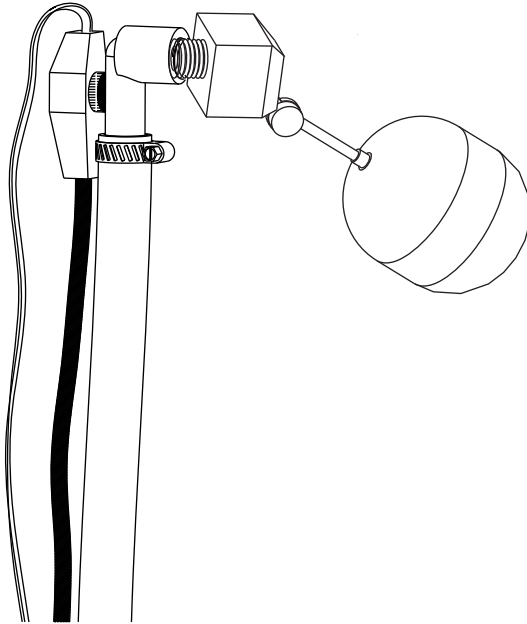

2

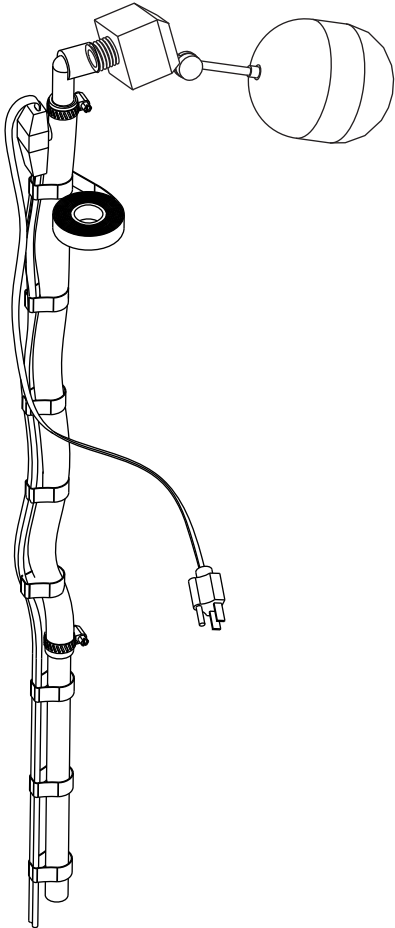

3

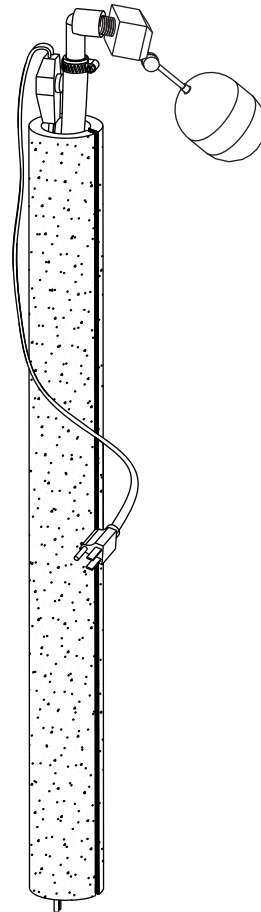

Warranty Policy



It is the goal of SPI Industries Inc. to provide our customers with the finest in livestock watering equipment products.

SPI provides a 10 (ten) year warranty on any purchase of our livestock watering equipment, which includes the models listed below. This warranty covers defects in the material or workmanship. The warranty however, is limited only to the value of the defected part and does not include any freight charges, loss of production and/or changes in operation. It does not cover damage due to careless machine handling and neglect. Proof of purchase is required.

Electric Models**:	EE10NG; VS15E; VS20E; VS20LPE
Energy Free Models:	351NG; 352NG; 354NG
Tip Tanks:	TIPTANK4,NG; TIPTANK7,NG
XL Series:	7XL; 10XL; 12XL
Stock Tanks:	35GALLON;100GALLON;150GALLON
Troughs:	TROUGH7
Value Series:	VS15; VS20; VS20LP

SPI provides a 1 (One) Year Warranty for:

- Float and Valve
- Door Hinges
- Submersible Heater and Heat Tape

Water Pressure: *The valve is appropriate for water pressure up to 55 psi.*

*****Note: To ensure the life of your electric livestock waterer be sure that the waterer is drained and shut off when not in use.***

Copyright © 2004 - 2017
SPI Industries Inc. All rights reserved
Printed in Canada

Updated: July 2015

Box 100, R.R.#2
Shallow Lake, ON N0H 2K0 Canada

[T] 800-269-6533 or 519-935-2211
[F] 519-935-2174

spi@spiplastics.com
www.spiplastics.com

