

CastleRock™ Installation

Thank you for purchasing our **CastleRock™** product. This product is designed for ease of installation and flexibility for a variety of configurations. Using a minimum of tools and labour an elegant wall or barrier fence can be constructed. These installation notes are to assist you in getting started with your **CastleRock™** project.

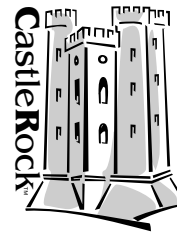

CastleRock™

CastleRock™ Design Features

- Nests when installed vertically for positional stability.
- One end designed to accept a bollard or another wall section for end-to-end connections.
- Has moulded in recesses (in the mortar lines) to enable the securing of a **CastleRock™** to another **CastleRock™** when stacking vertically or end-to-end.
- Different stone patterns (on the front and back faces) enable a pseudo random stone pattern in multi **CastleRock™** wall designs.
- Can be joined to another **CastleRock™** (up to 90 degree angles) creating curves and angles.

Various Assembly Suggestions

- **CastleRock™** can be set directly on the ground or a prepared base. Secure the wall to the ground with hardware appropriate for the circumstance (eg. concrete anchors/Tapcon screws for a concrete base, posts in footings, or super spike for earth/gravel installations).
- Secure a wall-to-wall or wall-to-bollard using #12 by 3 inch rustproof screws.
- In vertical wall configurations a steel or wooden post must be run up through the bollard ends of the wall to give stability.

CastleRock™ Parts

- Using 2 (two) parts your design possibilities are endless.
- Below these 2 (two) parts are detailed:



CastleRock™
Bollard
Part # CRB

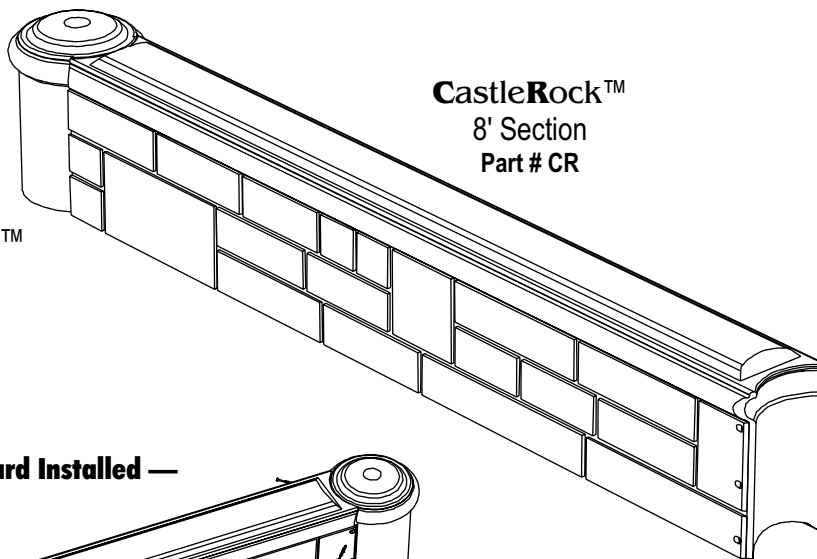

CastleRock™
8' Section
Part # CR

— **CastleRock™ with Bollard Installed** —

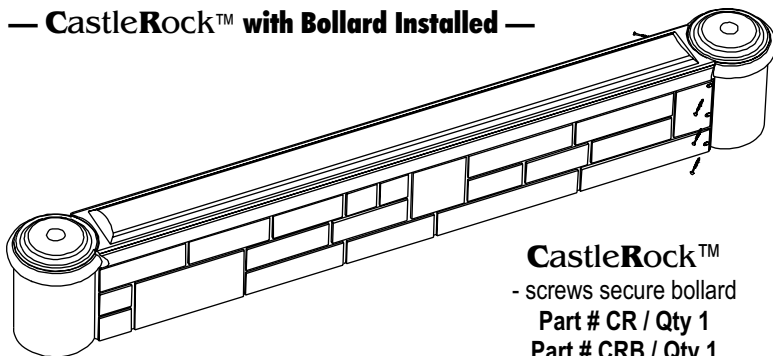

CastleRock™
- screws secure bollard
Part # CR / Qty 1
Part # CRB / Qty 1

CastleRock™ Installation *(continued)*

CastleRock™ Configuration Examples

— Two or More Sections —

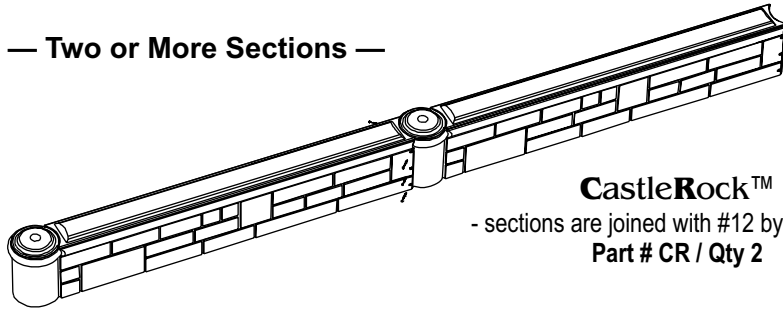

CastleRock™

- sections are joined with #12 by 3" screws
Part # CR / Qty 2

— Stacking Two or More Sections —

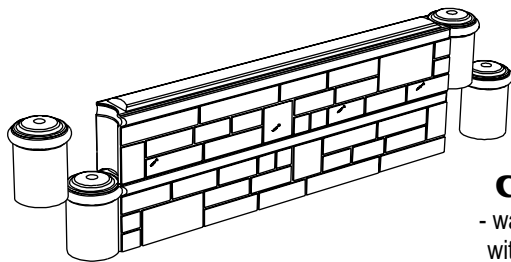

CastleRock™

- wall sections attached with #12 by 3" screws
Part # CR / Qty 2
Part # CRB / Qty 2

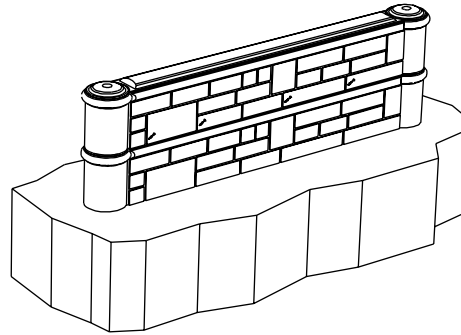

— Sections Creating a Continuous Wall —

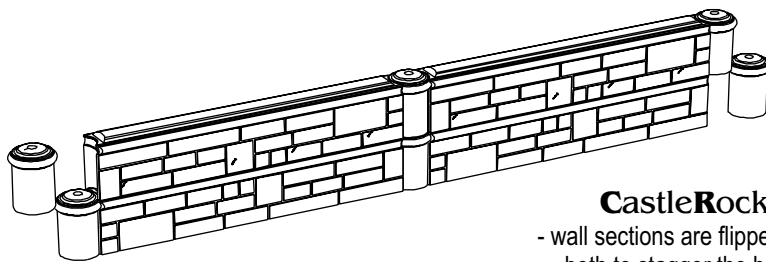

CastleRock™

- wall sections are flipped around both to stagger the bollards and the stone faces
Part # CR / Qty 4
Part # CRB / Qty 2

Note: Installation of wall systems greater than 40' (12.2 m) in length require an expansion joint at each 32' (9.8 m) increment. This is created with a butt joint of the bollards of the adjoining wall sections.

— Connections Using Angles —

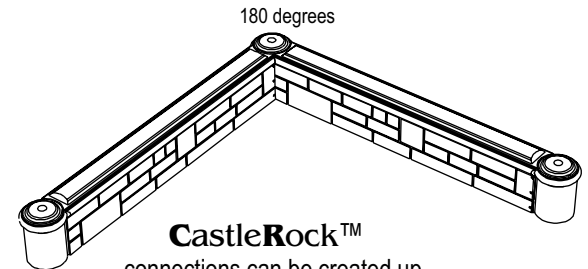

CastleRock™

- connections can be created up to a 90 degree angle
Part # CR / Qty 2
Part # CRB / Qty 1

CastleRock™ Vertical Wall Installation Example

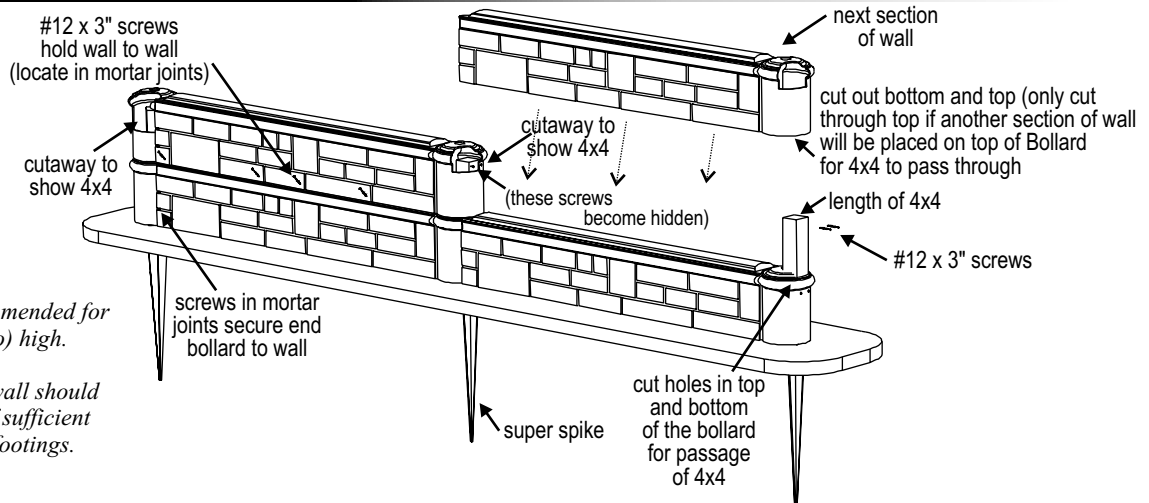

Notes:
Super Spike is not recommended for walls greater than 2 (two) high.

Above 2 (two) tiers the wall should be supported by posts of sufficient strength set in concrete footings.

CastleRock™ Installation *(continued)*

CastleRock™ Retaining Wall Installation Example

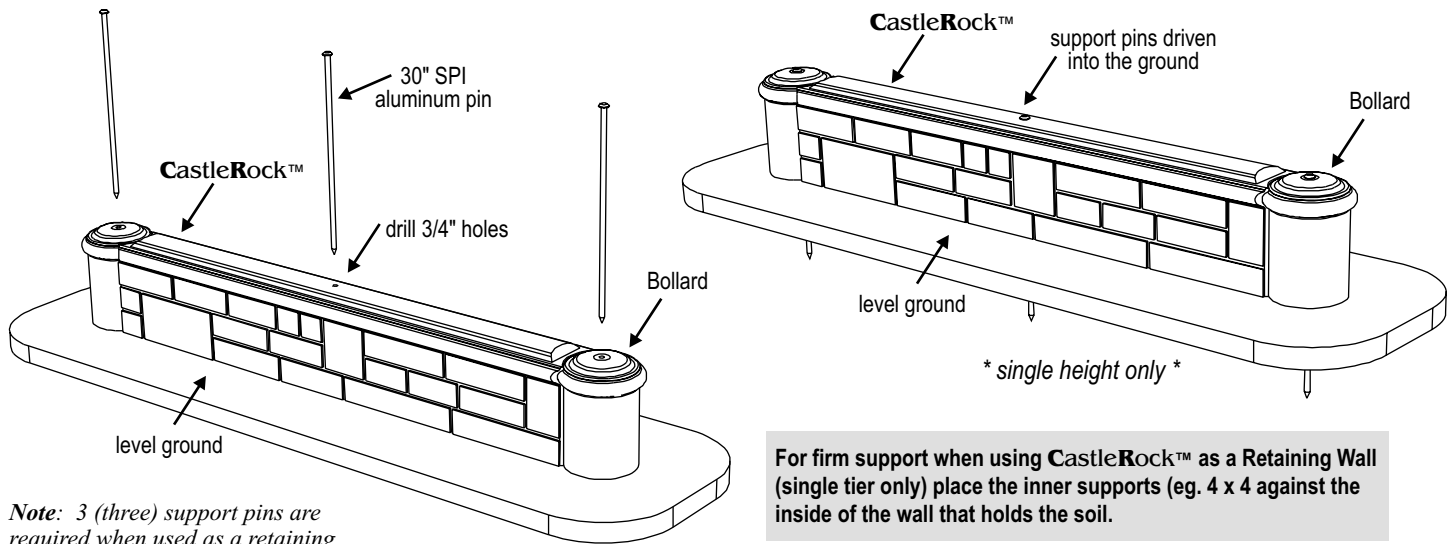

Note: 3 (three) support pins are required when used as a retaining wall or use 4x4 in ground

CastleRock™ 4x4 Post Installation Example

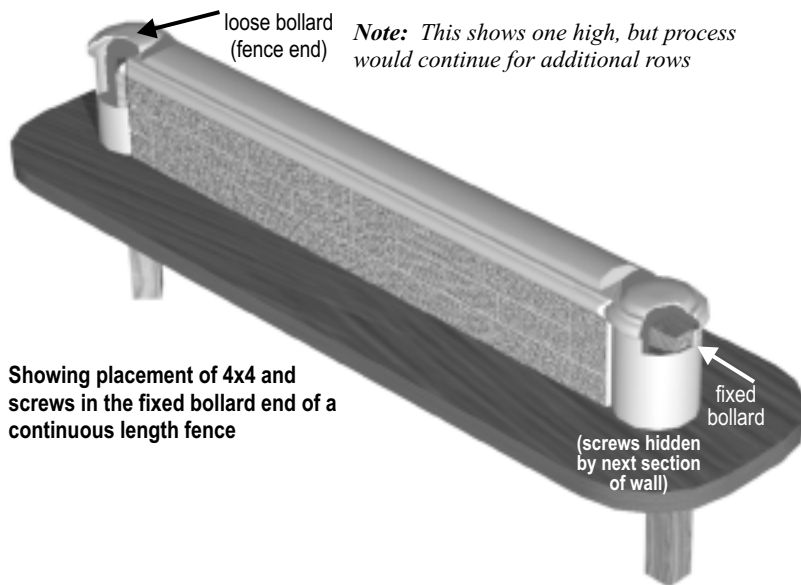
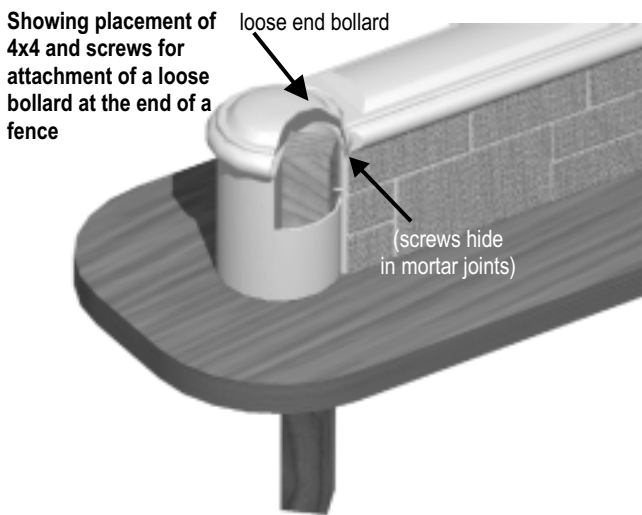

Plan View —

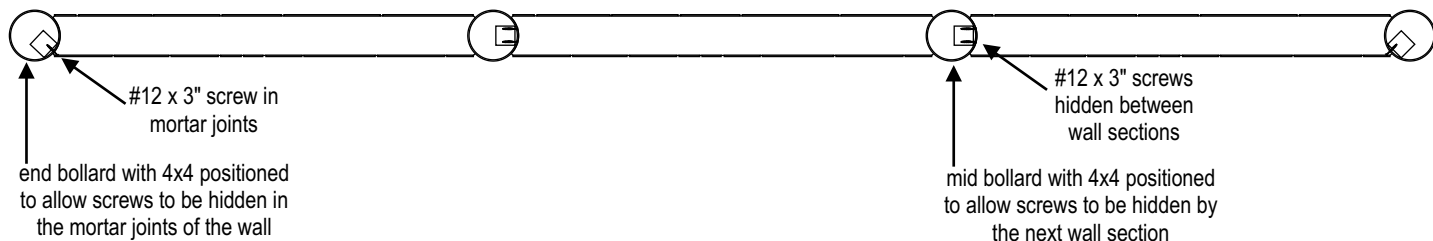

Note: Placement of 4x4's in the correct position may be made easier by cutting the bottom of the Bollard out.

CastleRock™ Installation *(continued)*

CastleRock™ Cutaway Views for 4x4 Mounting

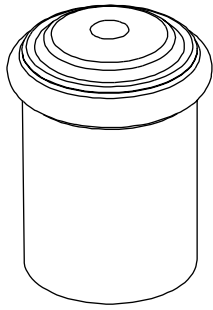

CastleRock™
Bollard
Part # CRB

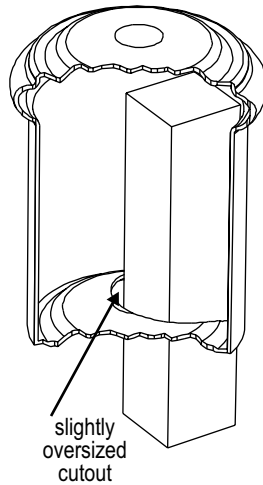

slightly oversized cutout

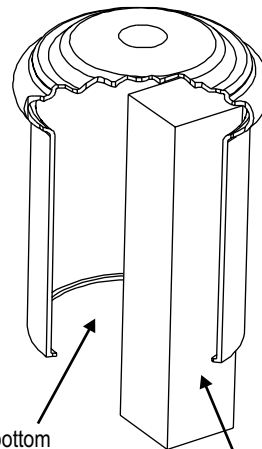

bottom cut out for maximum clearance

4 x 4 mounting post

— Enlarged View of End Bollard —

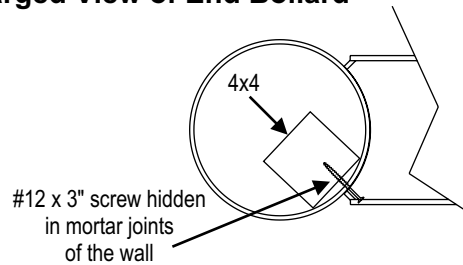

#12 x 3" screw hidden in mortar joints of the wall

— Enlarged View of Mid Bollard —

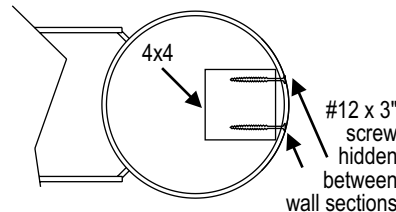

#12 x 3" screw hidden between wall sections

Positioning of posts may be easier by cutting out a hole in the CastleRock™ with lots of clearance.

Recommended Depth/Size of Support Posts/Diameter of Footing

5 units high (free standing)

you would need:

Sch. 40 Steel Pipe 3" dia.

or

Pressure Treated Wood 6" dia.

in

Soft Soil 3.75'

Good Soil 2.5'

with

12" diameter cement footing

2 units high (as a freestanding wall)

you would need:

Sch. 40 Steel Pipe 2" dia.

or

Pressure Treated Wood 4" dia.

in

Soft Soil 3'

Good Soil 2'

with

12" diameter cement footing

1 unit high (as an edging or retaining wall)

you would need:

Sch. 40 Steel Pipe 1.25" dia.

with

Pressure Treated Wood 4" dia.

or

30" SPI Aluminum Pin

in

Soft Soil 2'

Good Soil 1.5'

with

8" diameter cement footing

Note: recommended depths exclude frost cover

CastleRock™ Distributed By:



Updated: February 27, 2004

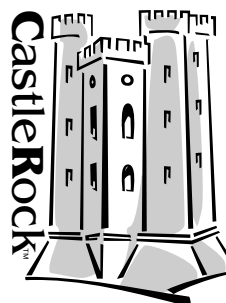

Manufacturer:

SPI Industries Inc.

P.O. Box 10, R.R. #2

Shallow Lake, Ontario N0H 2K0

Tel: 800-269-6533 or 519-935-2211

Fax: 519-935-2174

Web: www.spiplastics.com

Email: spi@spiplastics.com

CastleRock™



Copyright ©2003 SPI Industries Inc.
All rights reserved.