

7

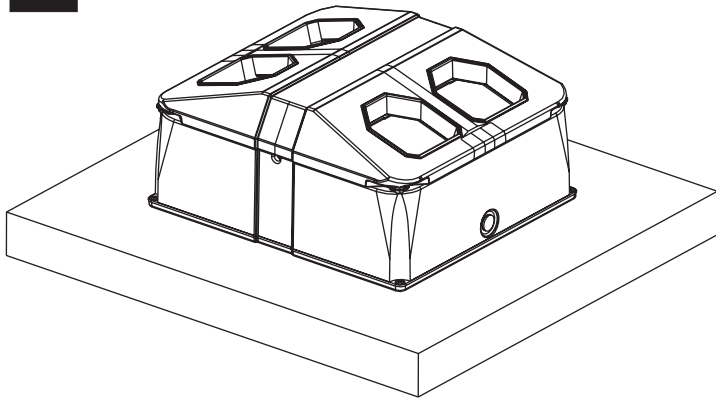

8

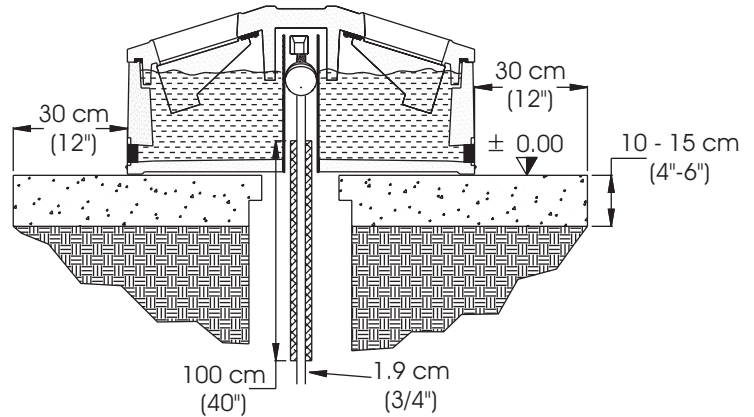

Copyright © 2004 - 2008
SPI Industries Inc. All rights reserved
Printed in Canada

Water Pressure: Please note the Franklin Valve is appropriate for water pressure up to 55 psi. If higher than this you will require a high pressure oriface for the valve.

Updated: November 2009

Warranty Policy

It is the goal of SPI Industries Inc. to provide our customers with the finest in livestock watering equipment products.

SPI provides a 5 (five) year warranty on any purchase of our livestock watering equipment, which includes the models listed below. This warranty covers defects in the material or workmanship. The warranty however, is limited only to the value of the defected part and does not include any freight charges, loss of production and/or changes in operation. It does not cover damage due to careless machine handling and neglect.

Electric Models:	EE10NG; EE50; EE100; VS15E; VS20E; VS20LPE
Energy Free Models:	351NG; 352NG; 354NG
Tip Tanks:	TIPTANK4,NG; TIPTANK7,NG
XL Series:	7XL; 10XL; 12XL
Stock Tanks:	35GALLON;100GALLON;150GALLON

SPI provides a 1 (One) Year Warranty for:

- Float and Valve
- Electrical Heating Pad
- Thermostat
- Submersible Heater and Heat Tape

Note: To ensure the life of your electric livestock waterer be sure that the waterer is drained and shut off when not in use.

Water Pressure: The Franklin Valve is appropriate for water pressure up to 55 psi. If higher than this you will require a high pressure oriface for the valve.

Copyright © 2004 - 2008
SPI Industries Inc. All rights reserved
Printed in Canada

Updated: November 2009

Box 100, R.R.#2
Shallow Lake, ON N0H 2K0 Canada

Tel: 800-269-6533 or 519-935-2211
Fax: 519-935-2174

Email: spi@spiplastics.com
Web: www.spiplastics.com